

ZC-1
wykonanie
specjalne

KUREK KULOWY - wykonanie wg wymagań specjalnych

DN15; 20

PN16; 25; 40

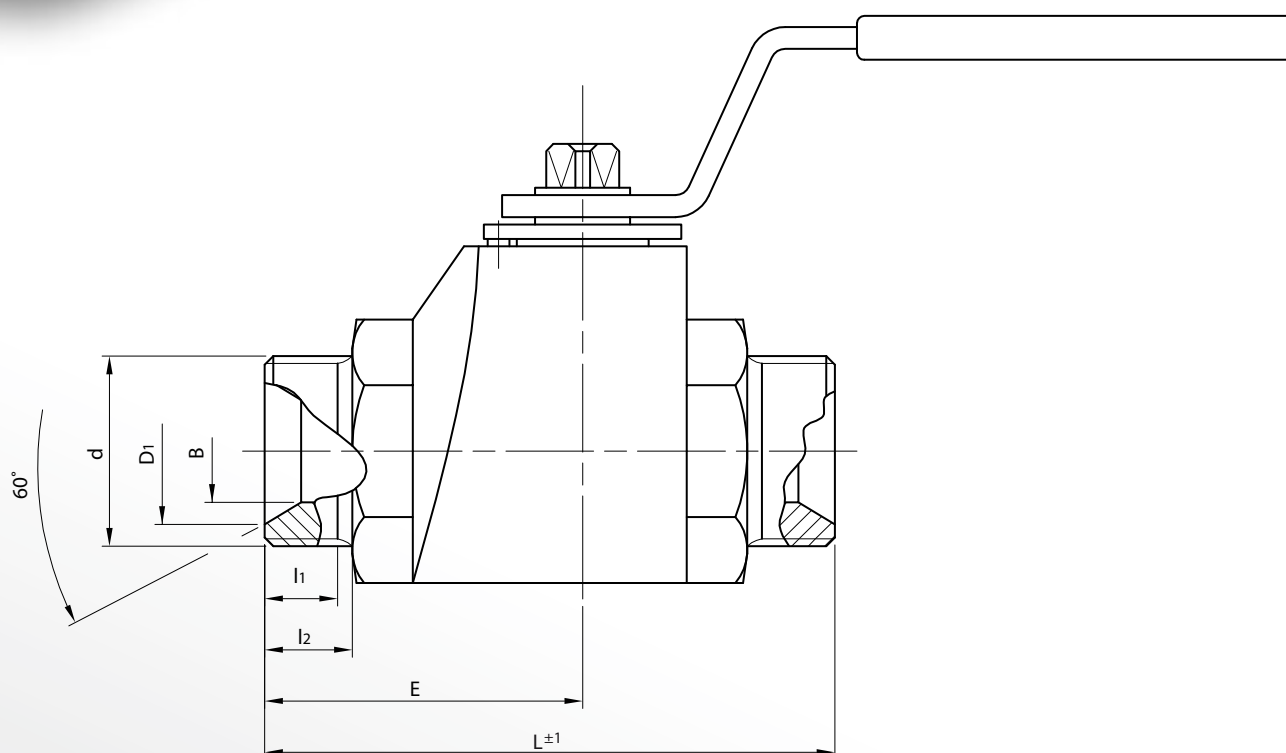

| DN | d | B | l ₁ | l ₂ | L | E | D ₁ | MASA |
|----|------------------|----|----------------|----------------|-----|------|----------------|------|
| | | | | | | | | ~kg |
| mm | | | | | | | | |
| 15 | G ^{3/4} | 15 | 9,5 | 12 | 80 | 44,5 | 20 | |
| 20 | G1 | 20 | 15,5 | 18 | 108 | 58 | 26,5 | |